

## Part A

## Predictions

Name \_\_\_\_\_.

1. Predict the currents in the circuit. Label each with an arrow to indicate direction and give each different current a different label, i.e.  $I_1, I_2, I_3, \dots$

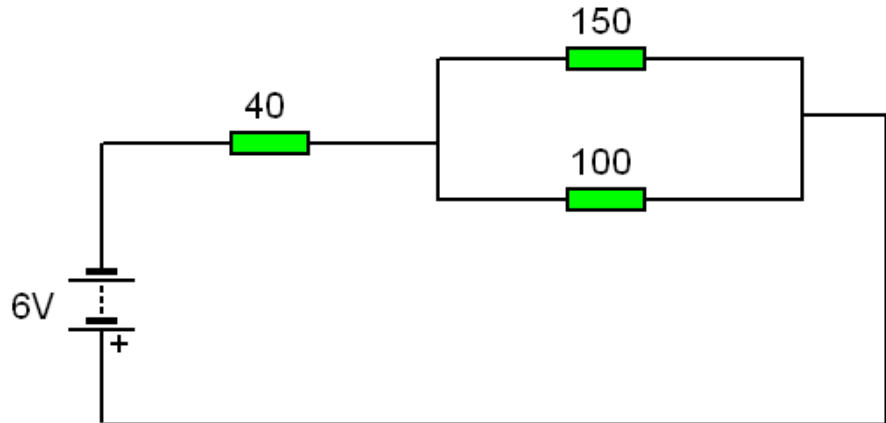

2. Plot the voltage in the circuit. (It is recommended that you draw in the currents on the plot.)

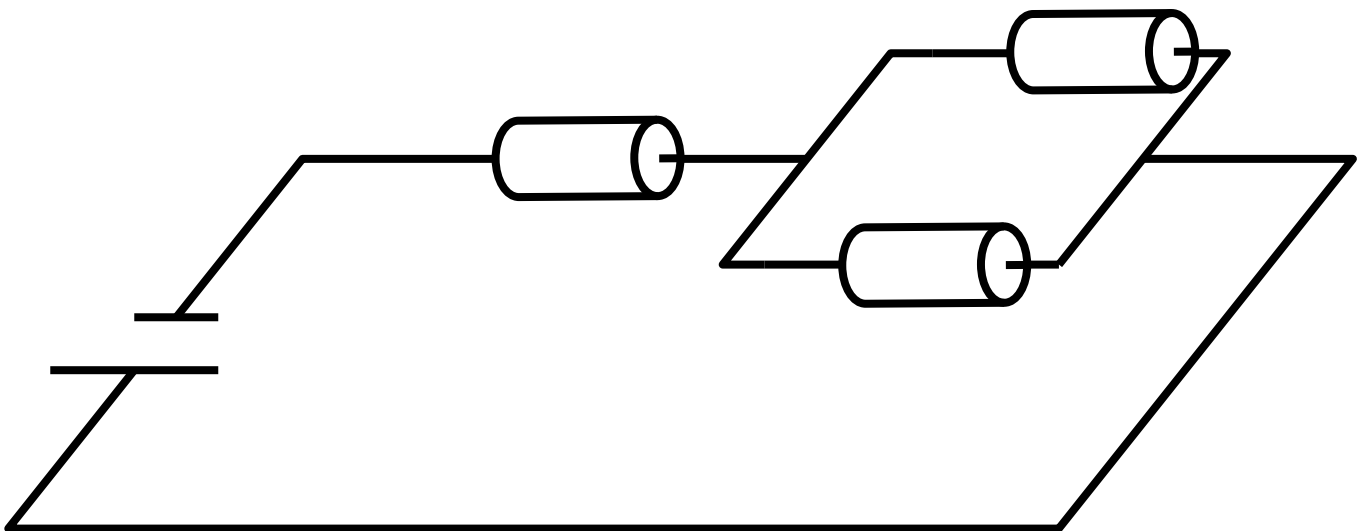

3.  
Explain the rules and concepts you used in your calculations

---

---

---

---

---

---

---

---

---

---

---

Calculate the voltage dropped across each resistor and all the currents in the circuit.  
**Show all work and equations including substitution with units.**

-Stop-

Part A

Results

Name \_\_\_\_\_.

1. Record the currents in the circuit. Record the voltages dropped across each resistor. (**Include Units**)

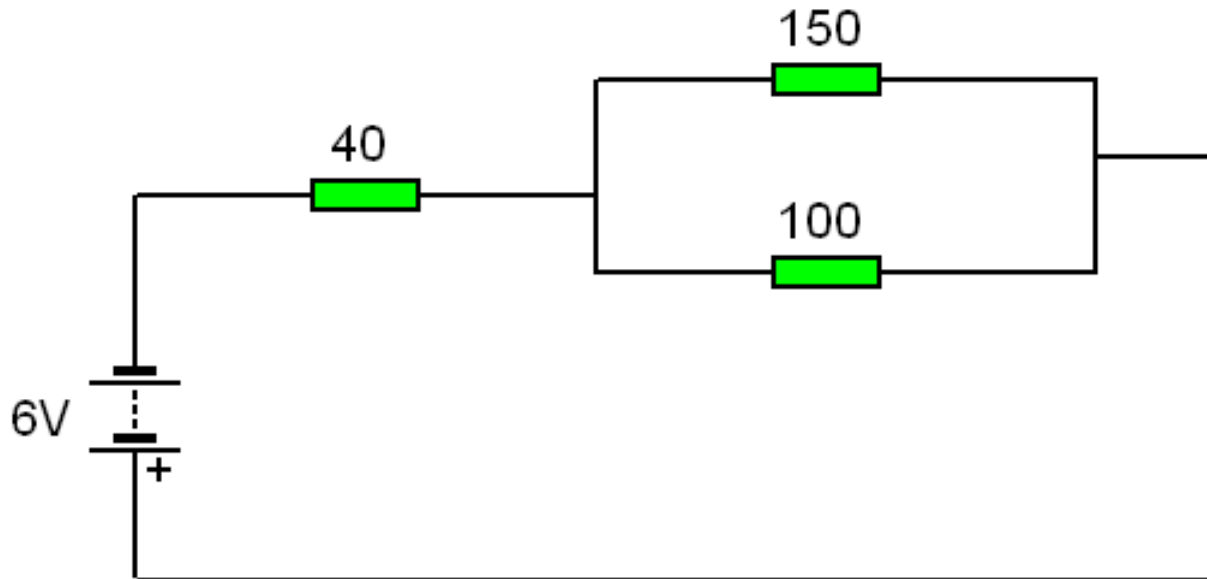

2. Explain any differences between your prediction and the results you found.

---

---

---

---

-Stop-

Part B

Predictions

Name \_\_\_\_\_.

1. Predict the currents in the circuit. Label each with an arrow to indicate direction and give each different current a different label, i.e.  $I_1, I_2, I_3, \dots$

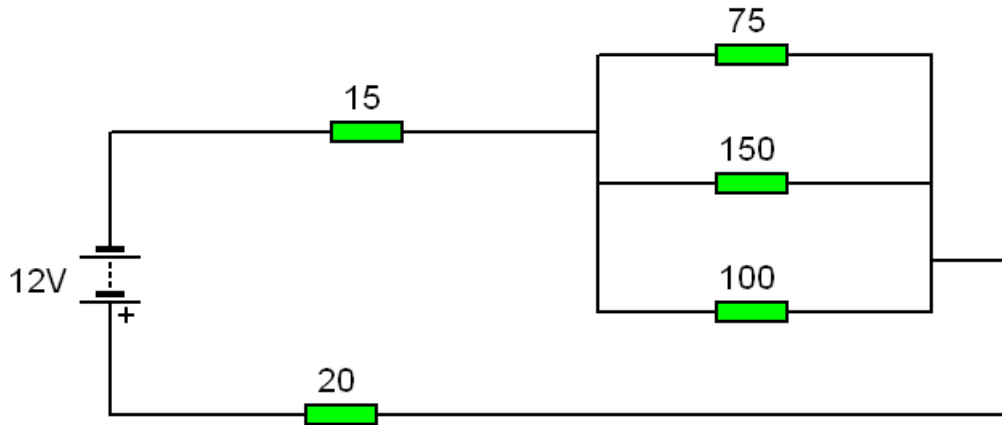

2. Plot the voltage in the circuit. (It is recommended that you draw in the currents on the plot.)

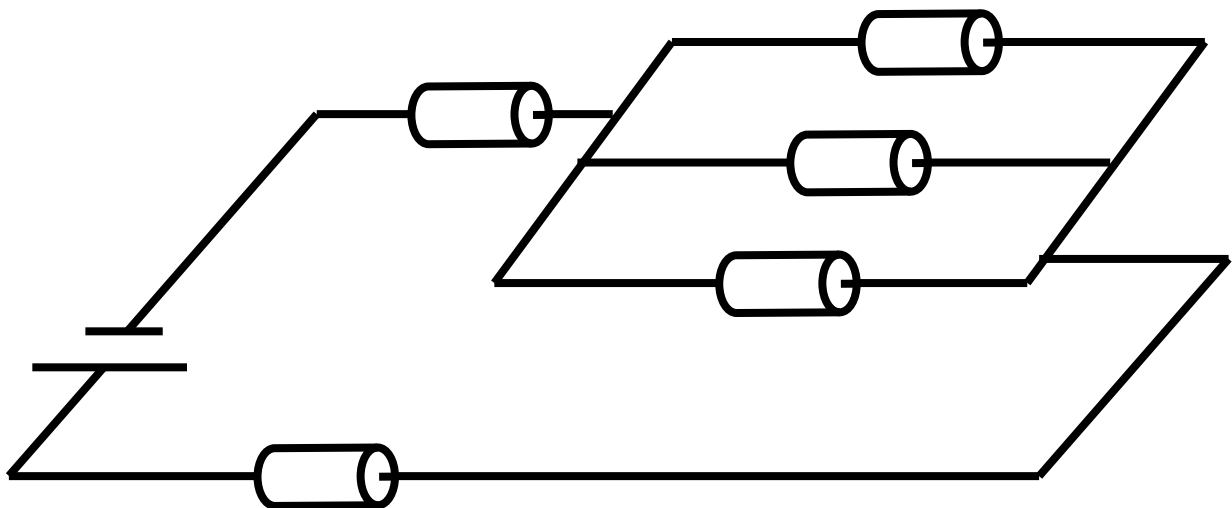

3.  
Explain the rules and concepts you used in your calculations

---

---

---

---

---

---

---

---

---

---

---

Calculate the voltage dropped across each resistor and all the currents in the circuit. **Show all work and equations including substitution with units.**

-Stop-

Name \_\_\_\_\_.

1. Record the currents in the circuit. Record the voltages dropped across each resistor. (**Include Units**)

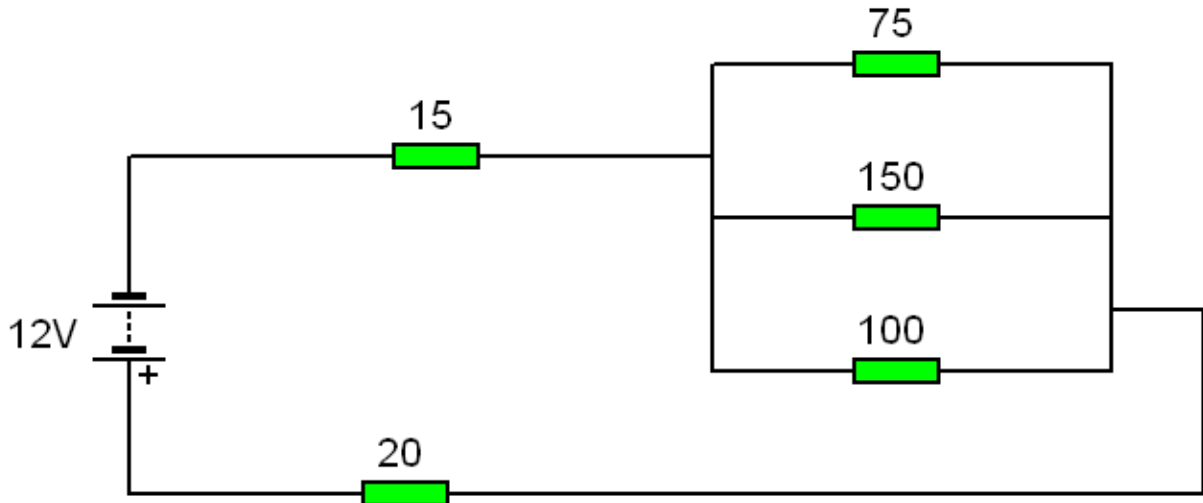

2. Explain any differences between your prediction and the results you found.

---

---

---

---

-Stop-

Name \_\_\_\_\_.

1. Predict the currents in the circuit. Label each with an arrow to indicate direction and give each different current a different label, i.e.  $I_1, I_2, I_3, \dots$

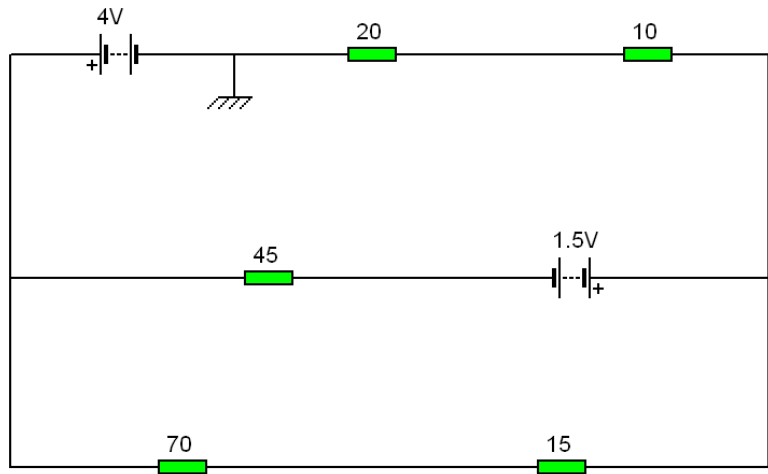

2. Plot the voltage in the circuit. (It is recommended that you draw in the currents on the plot.)

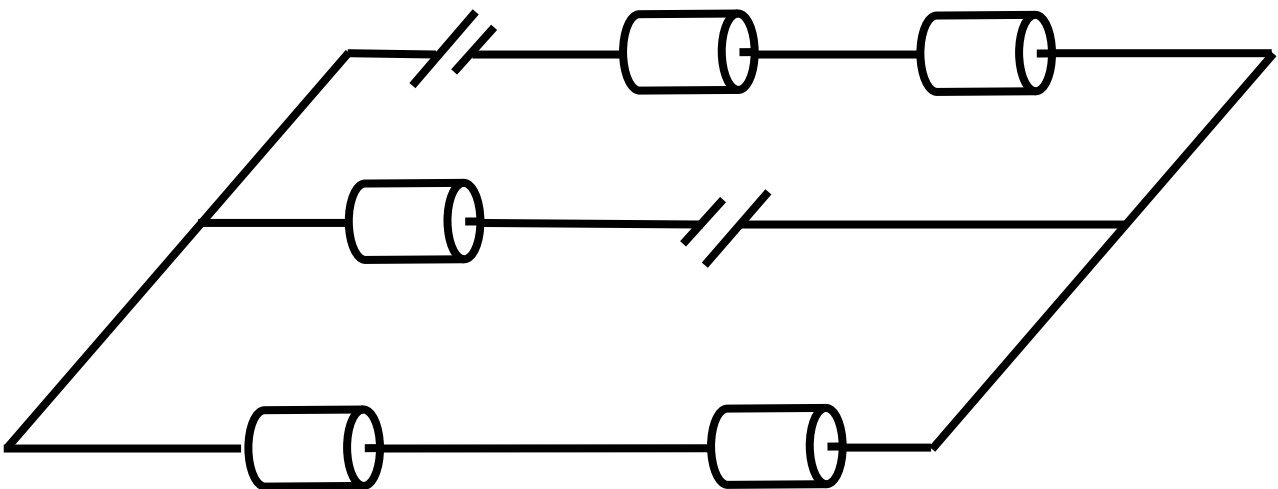

3.  
Explain the rules and concepts you used in your calculations

---

---

---

---

---

---

---

---

---

---

---

Calculate the voltage dropped across each resistor and all the currents in the circuit.  
**Show all work and equations including substitution with units.**

-Stop-

Part C

Results

Name \_\_\_\_\_.

1. Record the currents in the circuit. Record the voltages dropped across each resistor. (**Include Units**)

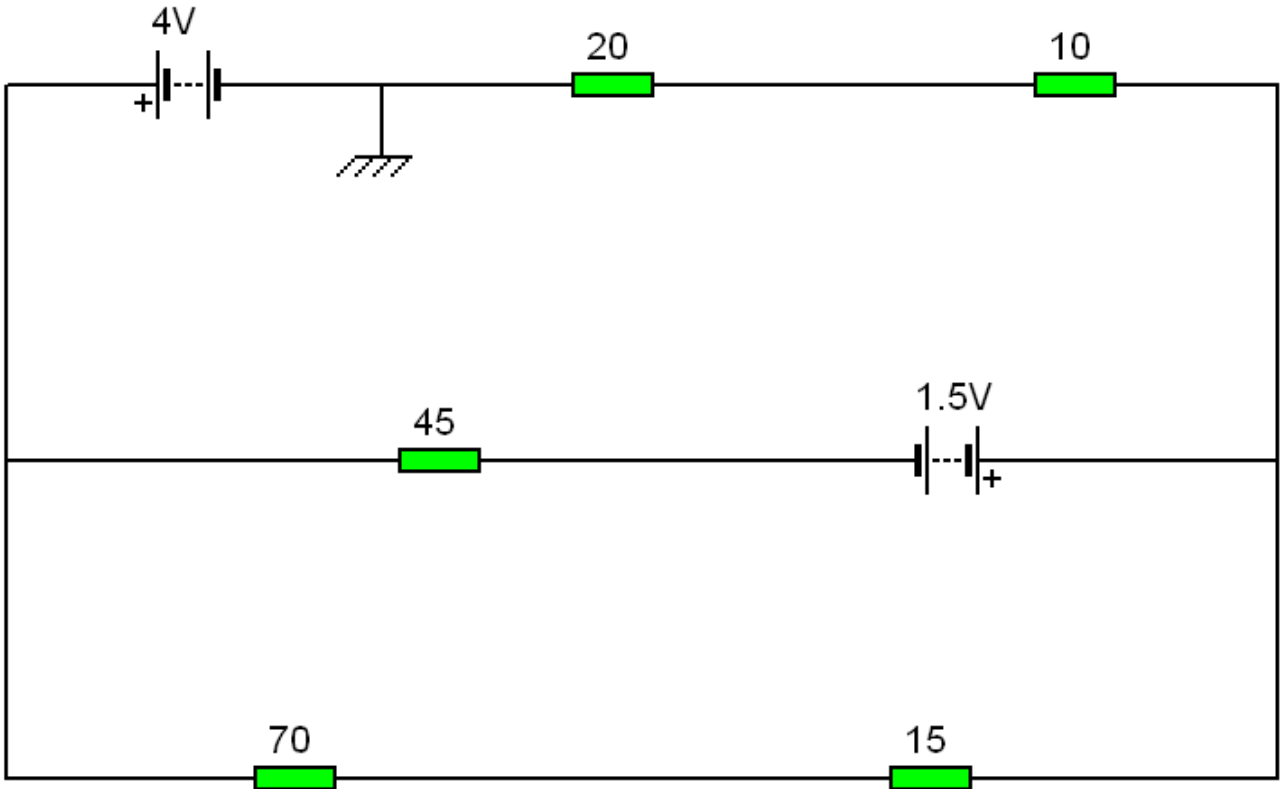

2. Explain any differences between your prediction and the results you found.

---

---

---

---

-Stop-

Part D

Predictions

Name \_\_\_\_\_.

1. Predict the currents in the circuit. Label each with an arrow to indicate direction and give each different current a different label, i.e.  $I_1, I_2, I_3, \dots$

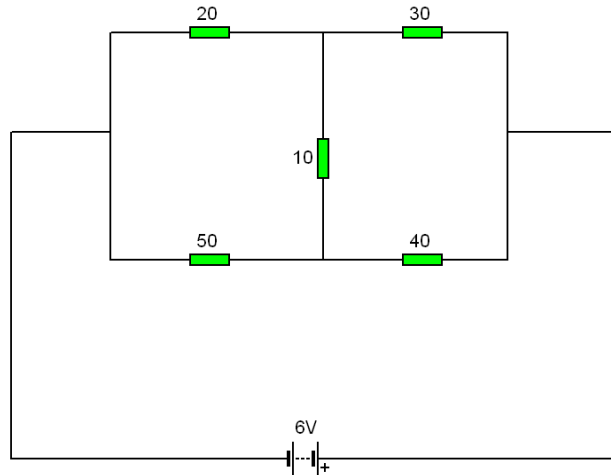

2. Plot the voltage in the circuit.

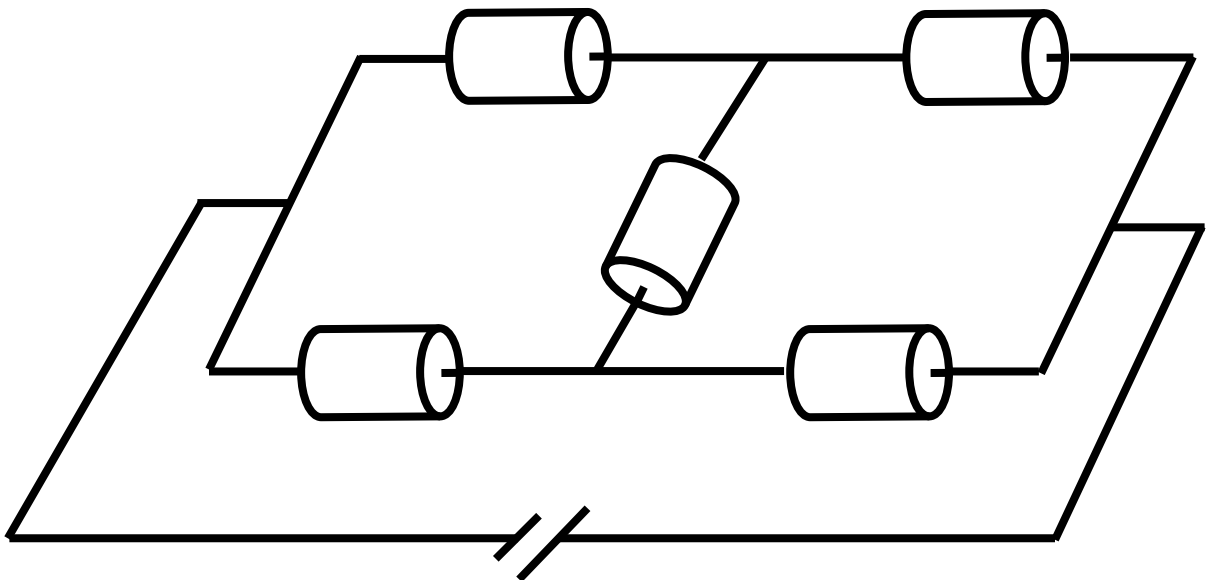

3.

Explain the rules and concepts you used in your calculations

Calculate the voltage dropped across each resistor and all the currents in the circuit.

**Show all work and equations including substitution with units.**

---

---

---

---

---

---

---

---

---

---

-Stop-

Part D

Results

Name \_\_\_\_\_.

1. Record the currents in the circuit. Record the voltages dropped across each resistor. (**Include Units**)

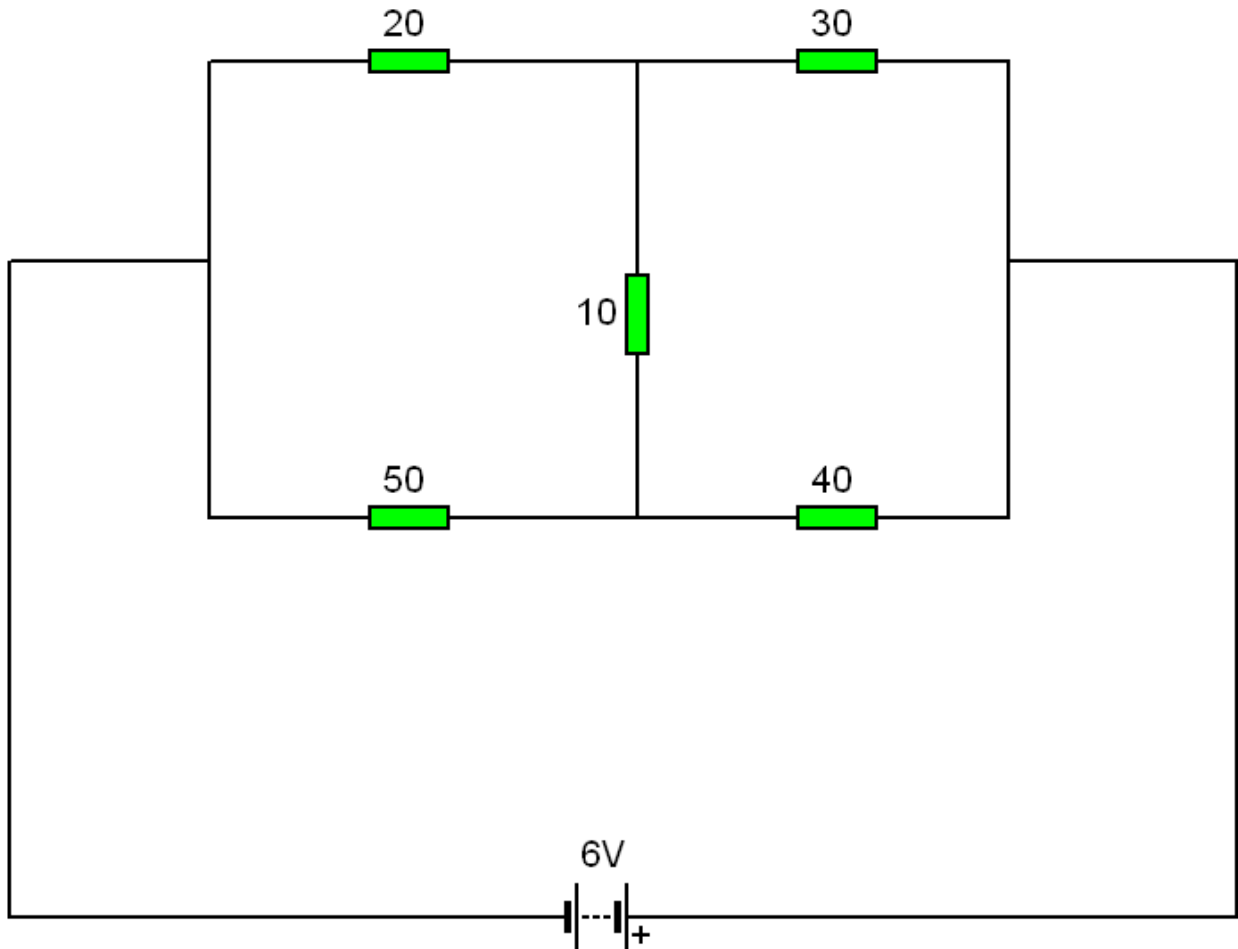

2. Explain any differences between your prediction and the results you found.

---

---

---

---